

FORD

INSTRUCTIONS

ADJUSTABLE STRUT ROD KIT

control freak
suspensions™

www.FreakRide.com



1962-65 Fairlane
1962-71 Falcon
1962-77 Comet
1963-71 Ranchero
1964-1973 Mustang
1966-71 Fairlane
1967-71 Cougar
1968-71 Torino
1969-71 Montego
1969-77 Maverick





SHORT STRUT ROD

1962-65 Comet

1962-65 Comet

1963-65 Ranchero

1964-66 Mustang



LONG STRUT ROD

- 1966-77 Comet
- 1966-71 Fairlane
- 1966-71 Falcon
- 1966-71 Ranchero
- 1967-73 Mustang
- 1967-71 Cougar
- 1969-71 Torino
- 1969-77 Maverick

OPTIONAL ADJUSTABLE STRUT RODS - INSTRUCTIONS

SHORT STRUT ROD TO LOWER CONTROL ARM MOUNTING

ITEM	PART NUMBER	DESCRIPTION	QUANTITY
1	43C175HC8Z	7/16"-14 X 1.75" HEX HEAD BOLT GRADE 8 YZ	2
2	43C125HC8Z	7/16"-14 X 1.25" HEX HEAD BOLT GRADE 8 YZ	4
3	43CNN8Z	7/16" -14 GRADE 8 NYLOCK NUT	6
4	43NWSHZ	7/16" SAE FLAT WASHER	12

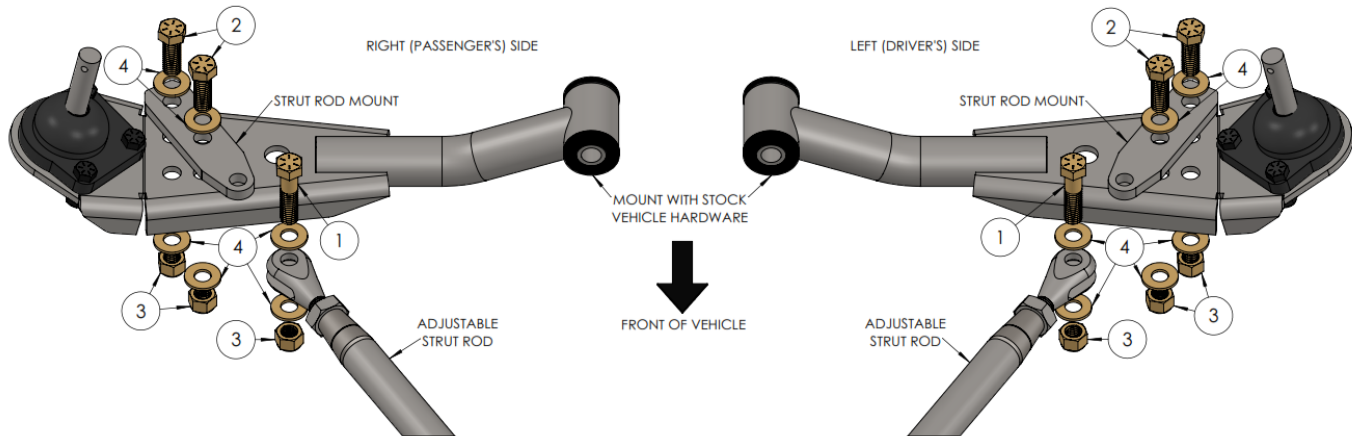

LONG STRUT ROD TO LOWER CONTROL ARM MOUNTING

ITEM	PART NUMBER	DESCRIPTION	QUANTITY
1	43C175HC8Z	7/16"-14 X 1.75" HEX HEAD BOLT GRADE 8 YZ	2
2	43C125HC8Z	7/16"-14 X 1.25" HEX HEAD BOLT GRADE 8 YZ	8
3	43CNN8Z	7/16" -14 GRADE 8 NYLOCK NUT	10
4	43NWSHZ	7/16" SAE FLAT WASHER	20

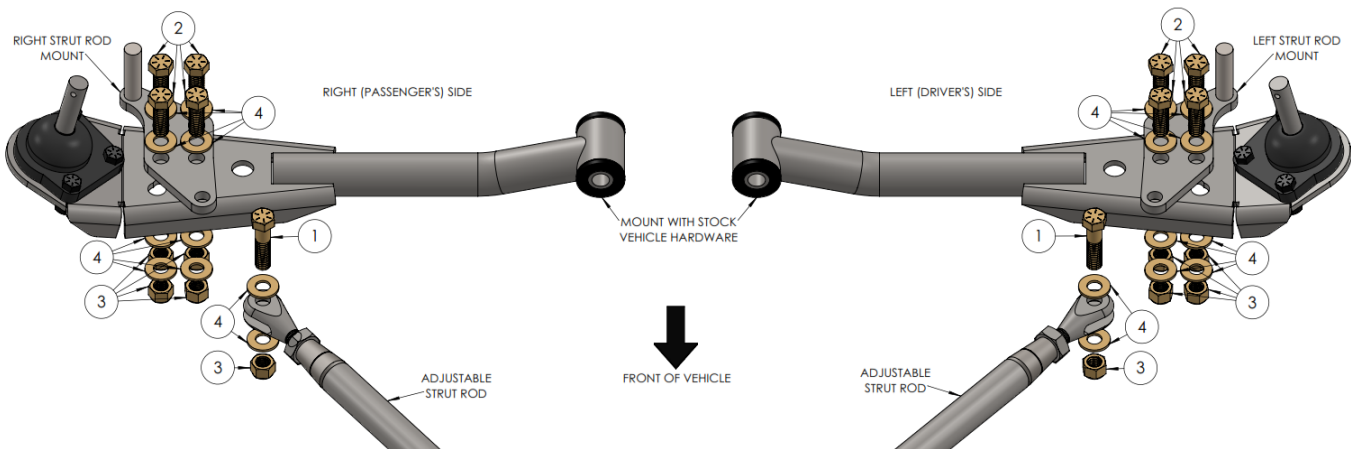

STRUT ROD TO CHASSIS MOUNTING - ALL YEARS

ITEM	PART NUMBER	DESCRIPTION	QUANTITY
1	50C275HC8Z	1/2" -13 X 2.75" HEX HEAD BOLT GRADE 8 YZ	2
2	50C175HC8Z	1/2" -13 X 1.75" HEX HEAD BOLT GRADE 8 YZ	2
3	50CNN8Z	7/16" -14 GRADE 8 NYLOCK NUT	4
4	50NWSHZ	7/16" SAE FLAT WASHER	8
5	XMR-8	1/2" -20 ROD END - RH THREADS	2
6	CA-2126	SPACER 0.75" x 0.12" DOM CL: 2.0625"	4
7	50FNFJ5Z	1/2" -20 JAM NUT RH THREADS	2

BOTTOM VIEW (CROPPED)

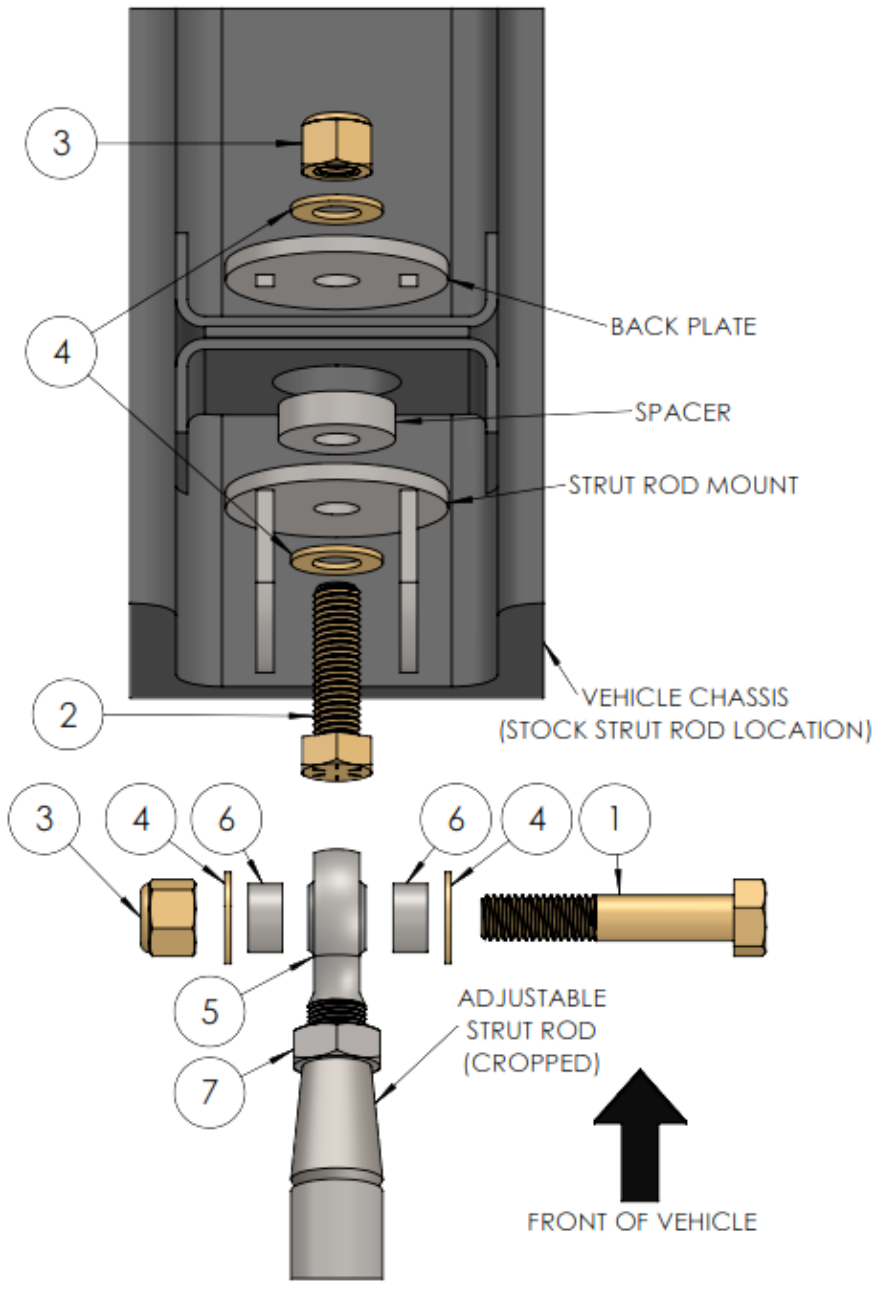

1. Attach the supplied strut rod mounts onto the lower control arm as shown in the illustration on Page 10. The 1962-66 mount has three holes and uses two (2) bolts for attaching to the lower control arm. The 1967-77 mount has five holes and a steering stop. It uses four (4) bolts for mounting to the lower control arm.
2. Attach the strut rod bracket to the strut rod mount on the chassis. The attachment is illustrated on Page 11. Torque the bracket to the specifications on Page 4.
3. Make sure the jam nuts are threaded onto the clevis and the rod end before installing them. Coat the threads with anti-seize before installing. Thread the clevis and the rod end into the appropriate ends on the strut rod. One thread is left-hand and the other is right-hand. The left-hand thread is marked on the strut rod with a machined line around the end. Attach the strut rod clevis end to the lower control arm with the supplied bolts, and the rod end to the strut rod bracket installed on the chassis. Torque all bolts to the specifications on Page 4. The length of the strut rod is adjustable for alignment purposes by loosening the jam nuts and turning the rod. Be certain to tighten the jam nuts once the correct alignment is completed.

IMPORTANT

DISCLAIMER In an effort to offer our customers value and service, Blue Moon Services LLC d/b/a Control Freak Suspensions (herein referred to as Control Freak) reserves the right to change suppliers, specifications, colors, prices, materials. Each of the previous items is subject to change without notice. Control Freak is not responsible for any typographical errors or misinterpretations. Quantities are limited on some items.

WARRANTY DISCLAIMER The purchaser understands and recognizes that racing parts, specialized high performance equipment, and all parts and services sold by Control Freak, are exposed to many and varied conditions due to the manner in which they are installed and used. Control Freak makes no warranties, either expressed or implied, including any warranty of merchantability or fitness for a particular purpose other than those contained in its current catalog with respect to the goods identified on the face of the invoice. There is no warranty expressed or implied as to whether the goods sold hereby will protect purchaser or ultimate user of such goods from injury or death. Control Freak assumes no liability for these suspension products.

DAMAGE CLAIMS Always inspect your package upon delivery. Inspect all packages in the presence of the delivery driver. The driver must note any damage. Ask the driver the Carrier's procedures for handling damage claims. You must hold the original box, packing material and damaged merchandise for inspection or the carrier will not honor the claim. Notify Control Freak for instructions on returning damaged goods. Control Freak is not responsible if no notification is given within two (2) days of receipt.

SHORTAGES Always check the contents of your delivery to insure all the parts that you ordered were received. Please read the invoice and Pack Lists. Double check all packing materials, small items may be wrapped inside with these products. Shortages may occur from damage to the box, so save all packing materials. Inspect the box for holes that would allow parts to fall out. If you are missing any item(s) be sure to check your invoice and/or Pack List for back orders or canceled items before calling the customer service department. If Control Freak has to split a shipment into multiple boxes, packages may be delivered on different days. You need to contact the customer service department within 5 days of delivery to assure the prompt replacement. Control Freak assumes no liability after this period.

WARRANTY CLAIMS If an item has a manufacturer's warranty as being free from defects we will exchange that item. If the item has been used and you are requesting warranty work, Control Freak will determine the validity of the claim. If you have any questions please contact customer service.

RETURNS Our return policy applies to all suspension systems **except** Independent Front Suspension (IFS) systems. Control Freak wants you to be satisfied with your purchase. If within five (5) days after you receive your shipment you are not satisfied, you may return the item for refund, exchange or credit. **This does not apply to any IFS systems.** All exchanged or returned merchandise must be in original factory condition with no modifications or alterations. Returned merchandise must include all original packaging materials, warranty cards, manuals, and accessories. If the items being returned need to be repackaged there will be a re-packing charge of 15%. Pack the item in a sturdy box and include a copy of your invoice and notify us of the return. You must ship orders back **PRE-PAID. WE DO NOT ACCEPT COD SHIPMENTS.** All exchanges need to have reshipping charges included. Items that are returned after 5 days are subject to 15% restocking charges. **Absolutely no returns on custom built suspension systems or other special order merchandise. All IFS systems are considered custom builds. All exchange and/or repair is at the discretion of Control Freak Suspensions.**

Some items may not be street legal in some countries. Such items may be legal for racing vehicles only which may not be used upon a highway

FORD

INSTRUCTIONS

ADJUSTABLE STRUT ROD KIT

control freak
suspensions™

www.FreakRide.com



CONTROL FREAK SUSPENSIONS

485 S. Shell Rd., Suite 5B

DeBary, Florida 32713

(407) 696-2772 (888) 325-6462 Toll Free (407) 696-6216 Fax

Sales@FreakRide.com

www.FreakRide.com