

FORD

MUSTANG / COUGAR 4-LINK TRIANGULATED SYSTEM

control freak

*suspensions*TM

www.FreakRide.com

INSTRUCTIONS

Triangulated 4-Link Coil Over Rear Suspension System

For FORD / MERCURY Muscle Cars:

**1965-1970 MUSTANG
1967-1969 COUGAR**

Revised: 10-1-2011



Tech Line: 888-325-6462

control freak
suspensions™

www.FreakRide.com

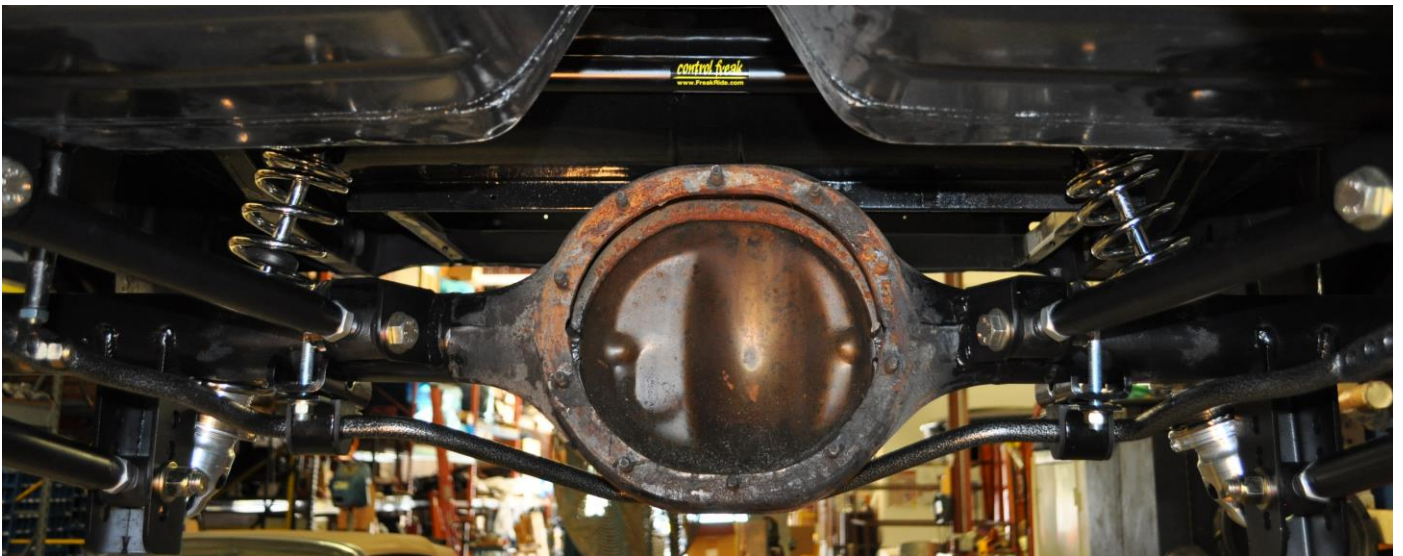
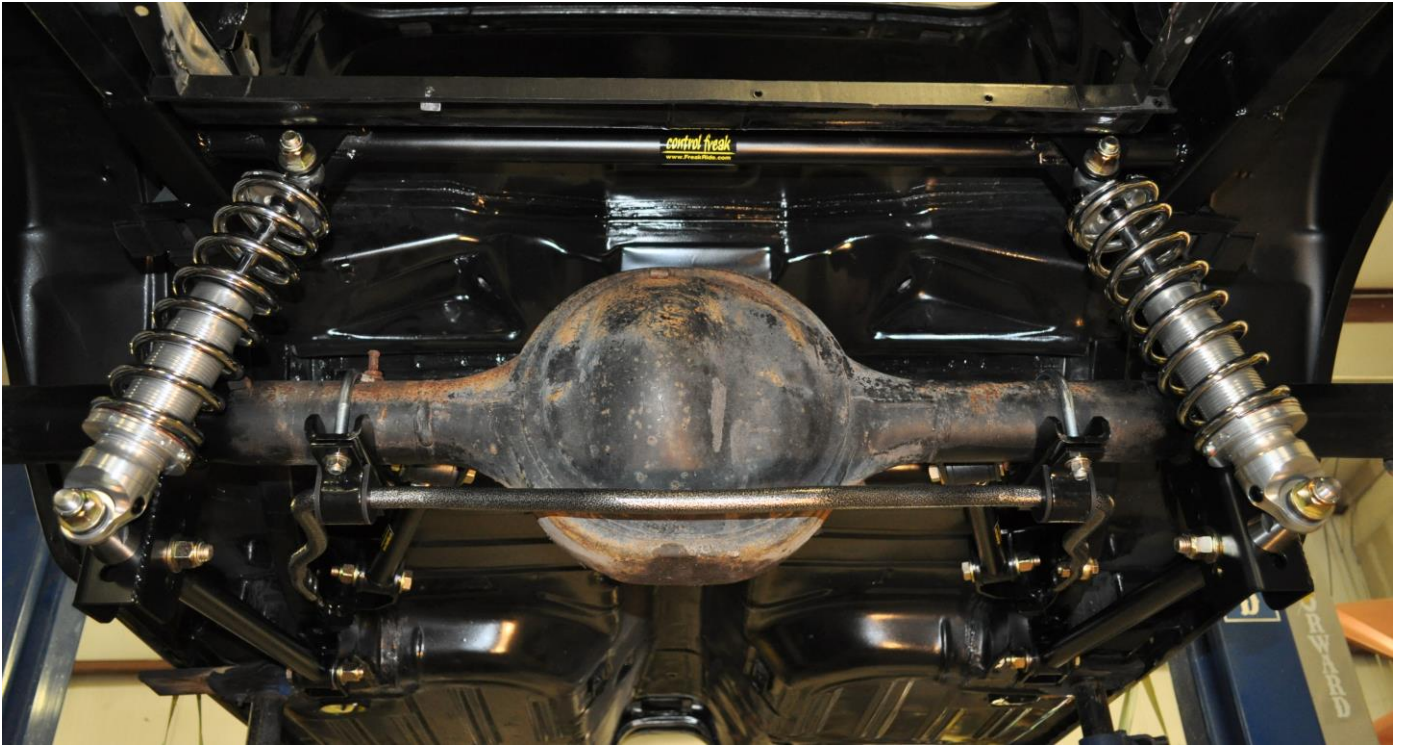

Installation Instructions

Vehicle: 1965-1970 Mustang
4-Link Triangulated Rear Suspension
Mustang Part # RS-2400
Cougar Part # RS-2460

Sub-Frame System Contents

- Two (2) Forward Frame Brackets – Raw Steel
- Two (2) Lower Differential Brackets – Raw Steel
- Two (2) Small Upper Trailing Arm Differential Brackets – Raw Steel
- One (1) Upper Coil Over Mount Bar – Raw Steel
- Two (2) Powder Coated Upper Trailing Arms with Adjustable End
- Two (2) Powder Coated Lower Trailing Arms with Adjustable End
- All Necessary Grade 8 Hardware

Thank you for purchasing a world-class Control Freak Suspensions® Ford Mustang / Cougar 4-Link Triangulated Rear Suspension kit, manufactured in Winter Springs, Florida. We believe this system is the best available at any price. As with any aftermarket performance product, this product is recommended for off road use only. This system is typically subjected to uses that exceed its mechanical limits, so there is no warranty, expressed or implied. Blue Moon Services LLC and its Control Freak Suspensions brand cannot control how this product is installed or used. By purchasing this product you are assuming all risks associated with its installation and use and agree to possess appropriate skills for its installation and use. Blue Moon Services LLC and its Control Freak Suspensions brand, our vendors and suppliers will not be held responsible, liable or accountable for any injury, damage, loss, penalties or fines that occur, directly or indirectly, from the installation and use of this product..

Please note that while installation is relatively easy for those with welding skills and moderate experience, novices should employ a professional for installation. Fit is guaranteed on vehicles that are unmolested...that is cars that have not suffered any chassis or significant sub-frame damage. Such damage can bend or alter the unitized body or chassis, making installation more difficult and may require chassis adjustment.

Read all of the instructions before starting installation.

IMPORTANT NOTES:

1. All brackets in this kit must be welded into place.
2. Use extra caution in jacking and stabilizing the vehicle for this installation. A lift is highly recommended.
3. Be certain to remove carpeting, insulation or other flammables from the area being welded or subjected to welding heat.

What Else Do I Need?

Everything you need is included in the purchase price. Installation requires welding. Disconnect your battery BEFORE welding. If you don't, you run the risk of ruining electronic ignition and entertainment components in the car.

Installation

1. Clean the metal of debris, rust, undercoating, paint or other elements in the bracket areas so shiny metal shows through. This provides a clean surface to weld to. On the differential, remove the stock spring perches and grind the welds smooth.

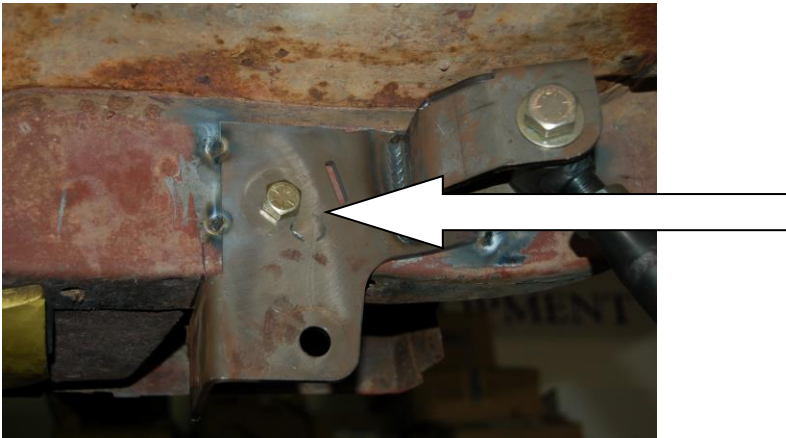

2. The most critical step is locating the forward frame brackets. Simply bolt the bracket to the forward leaf spring hole using the original bolt. This locates the forward frame brackets on each side of the vehicle. Just make certain it is vertical to the ground (90 Degrees to the frame)

3. Tack the forward frame brackets into place as shown in the picture above and to the right and remove the bolt.
4. Attach the upper and lower trailing arms to the forward frame brackets and hand tighten the nuts onto the bolts. Make certain the upper trailing arms are adjusted to the same length, with about three threads showing behind the jam nut. Do the same for the lower trailing arms.
5. You are now ready to put the differential into position. Place the differential **at ride height and center it** into the vehicle, making certain the housing flanges are the same distance from the frame rails on both sides of the car.
6. Measure the angle of the transmission tail shaft. You will transfer this same angle to the pinion, making certain the angle from the tail shaft is the same on the pinion of the differential unit. Once done, place a degree gauge on the driveshaft and determine the angle. You can now determine what the pinion angle is vs. where it should be. Adjust the differential by rotating it so it is between zero and minus one-half degree for street use **at ride height**. For track use you will need to determine the pinion angle based upon power, launch capability and other factors. Once the brackets are installed you will be able to make other adjustments. For now it is important to have a correct pinion angle and to have the housing centered in the vehicle.
7. Place the assembled trailing arms, with brackets attached, onto the differential. This dictates where the brackets should be. Once again, check the centering of the differential unit and the pinion angle. When it is all correct, tack weld all of the brackets into position.

8. Attach the machined studs to the rear lower trailing arm brackets and mount the coil over shocks to the studs. Place the upper coil over mount bar into



position, making certain the coil over shocks are correctly angled. They should be straight up and down. When satisfied, tack weld the bar into place.

Note that the upper coil over mount bar brackets have one side that is angled. That is the rear of the bar. On 1969-1970 Mustangs, the angles bracket should be about 3/16" away from the angled trunk sheet metal. On earlier vehicles it will be about 3/4" away. Regardless, the coil over shock should be perfectly vertical when bolted up and viewed from the side.

9. Check once again to make certain that the differential housing is at ride height, is centered in the vehicle and that the pinion

angle is still zero degrees. When confirmed, remove the trailing arms and loosen the axles from the differential housing. When welding the differential brackets, do a little at a time, making certain not to melt any seals on the axle tubes.

10. Once cooled, reassemble the system, making certain all bolts are tight. Check and re-check all bolts for correct tightness.
11. You can now adjust the coil over shocks leaving about 1" of threads showing below the height adjustment. Turn the valve all the way counterclockwise and then count ten turns clockwise. This will provide a preliminary setting for the coil over adjustments.
12. Do not worry if the vehicle is sitting higher than you expected. Set the coil overs to sit about 3/4" higher than where you want it because the shocks will settle by that amount after 15-20 miles of driving.
13. Check your pinion angle and make certain it is not more that negative 1/2 degree. Make necessary adjustments.



14. Congratulations...your system is installed.
15. If you purchased the adjustable rear sway bar, now is the time to install it. Refer to the directions included with the sway bar.

Check Out Our Other FORD Suspension & Go-Fast Goodies



Coil-Over Conversion Kits

65-70 Mustang
62-65 Fairlane
62-65 Comet
62-65 Falcon

4-Link Coil-Over Rear Suspension Kits

62-65 Fairlane
Falcon, Comet and other Fairlane's
Coming Soon

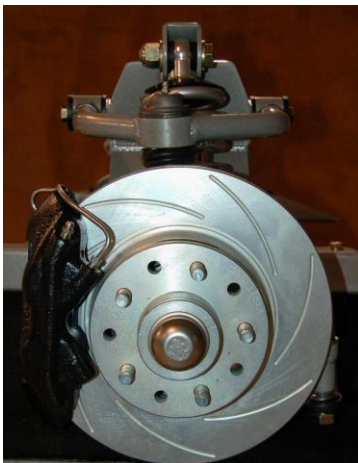
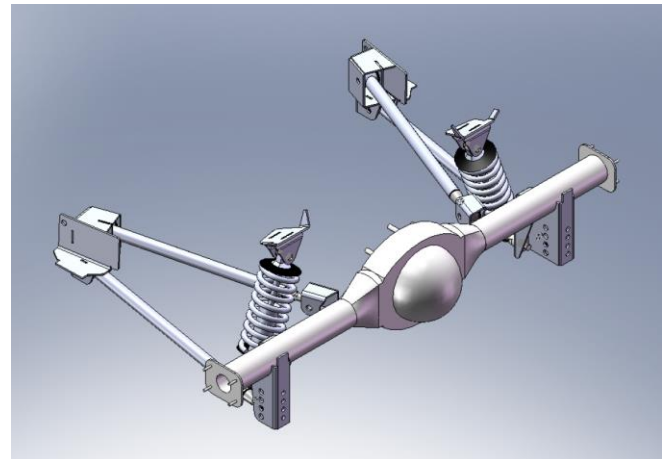

Brake Systems

From Wilwood, SSBC & Others

Disclaimer of Warranty

THE PURCHASER IS RESPONSIBLE FOR DETERMINING THE SUITABILITY OF ANY AND ALL PRODUCTS MANUFACTURED BY BLUE MOON SERVICES LLC

Purchaser understands and recognizes that racing parts equipment and services provided by, manufactured and/or sold by Blue Moon Services LLC d/b/a Control Freak Suspensions under the Control Freak Suspensions label, are subject to varied conditions due to the manner in which they are installed and used. Purchaser further recognizes and agrees that suitability of any part sold or manufactured by Blue Moon Services LLC d/b/a Control Freak Suspensions under the Control Freak Suspensions label for a particular application is the purchasers decision and that the purchaser is not relying on the skill or judgment of Blue Moon Services LLC d/b/a Control Freak Suspensions under the Control Freak Suspensions label regarding suitability of any product or service. Blue Moon Services LLC d/b/a Control Freak Suspensions under the Control Freak Suspensions label, makes no warranties whatsoever, expressed or implied, oral or written to purchasers. There is no warranty of merchantability made to purchasers with regard to off road, racing and racing equipment.

Liability is limited to repair or replacement of defective parts to original purchaser. Blue Moon Services LLC d/b/a Control Freak Suspensions is not liable for any consequential damages, expenses or injury arising from the use, misuse, or improper installation of any product manufactured or sold by Blue Moon Services LLC d/b/a Control Freak Suspensions under the Control Freak Suspensions label. Blue Moon Services LLC d/b/a Control Freak Suspensions reserves the right to make changes in design or add to or improve its product without incurring any obligation to install the same on any products previously manufactured. This warranty shall not apply to any product which has been repaired or altered in any way so as in our judgment to affect its performance; nor which has been subject to misuse, abuse, negligence or any other occurrence beyond the control of Blue Moon Services LLC d/b/a Control Freak Suspensions.

FORD

MUSTANG / COUGAR 4-LINK TRIANGULATED SYSTEM

Control Freak Suspensions
1101 Oak Lane, Suite 1031
Winter Springs, FL 32708
407-696-2772
888-325-6462 Toll Free
407-696-6216 Fax
www.FreakRide.com